

810

OWNERS MANUAL

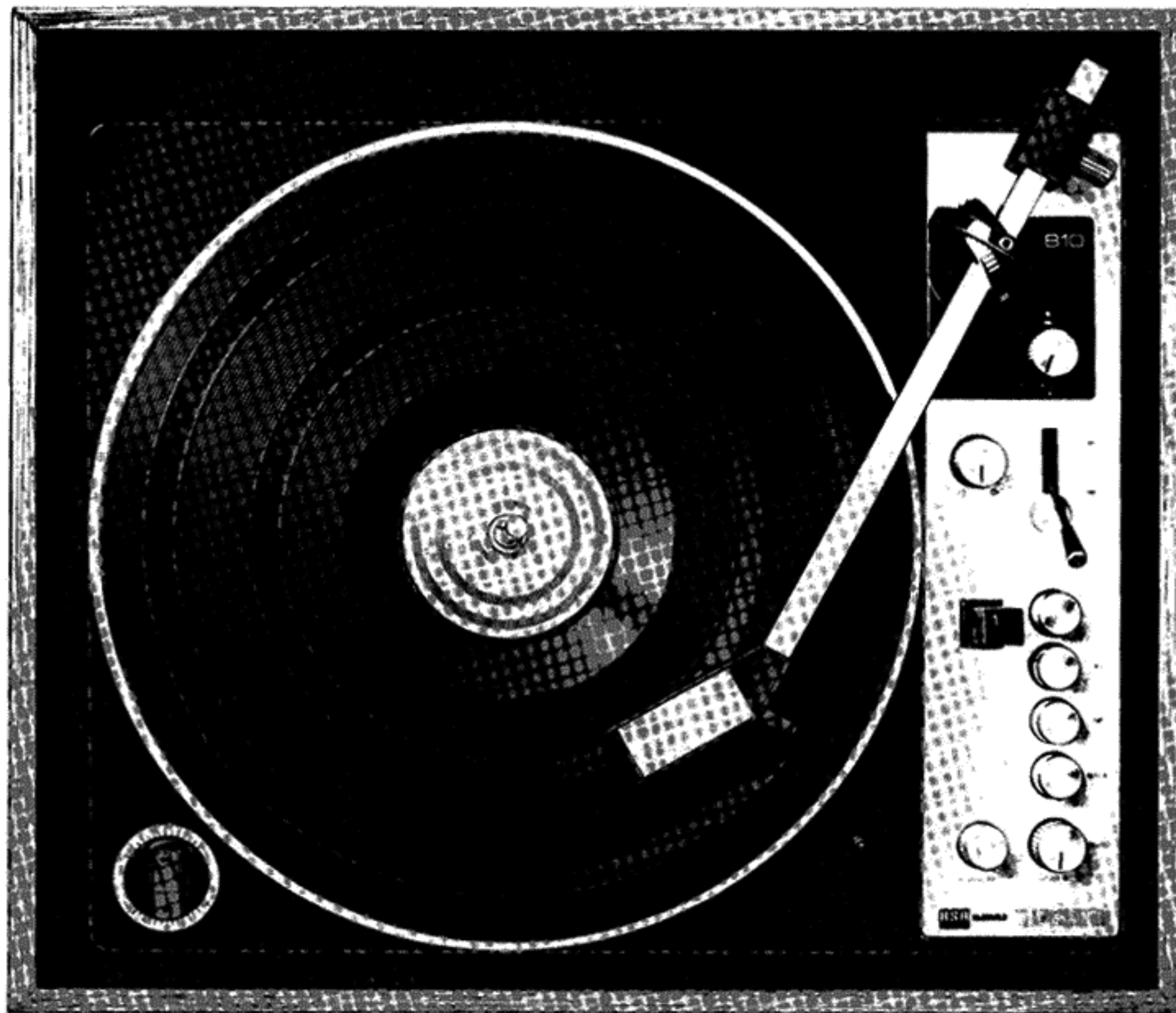

The 810 Transcription Series Turntable operates with flawless computer precision. Its pre-programmed sequential cam system introduces a new experience in smoothness, quietness and featherlight operation over the widest range of operating modes. The low mass aluminum transcription tonearm floats in a concentric gimbal arm mount, reducing tracking error to a mere 0.5° per inch, and offers precise zero balance adjustment over the full range of cartridge and stylus masses. Other significant developments combined in the 810 include a 7½ lb. 12 in. dynamically balanced diecast turntable with integral strobe disc, a high torque synchronous induction power unit, rotating variable pitch control with two-speed rocker action speed change, viscous damped cue and pause with exclusive friction clutch, automatic tonearm lock to prevent accidental damage to the stylus or record, a dual range anti-skate control and stylus overhang adjustment. The result – complete freedom from distortion and new life for your records. Please study the manual carefully to familiarise yourself with the many highly advanced sophisticated operating features. And now – good listening.

CONTENTS

DESIGN AND OPERATING FEATURES	Page 2
UNPACKING	Page 3
INSTALLATION	Page 3
ASSEMBLY	Pages 4 & 5

ADJUSTMENTS	Pages 6 & 7
CONNECTIONS	Page 8
OPERATING INSTRUCTIONS	Pages 9 & 10
FREQUENCY CHANGE	Page 10
LUBRICATION	Page 10
SERVICE	Page 10

DESIGN AND OPERATING FEATURES

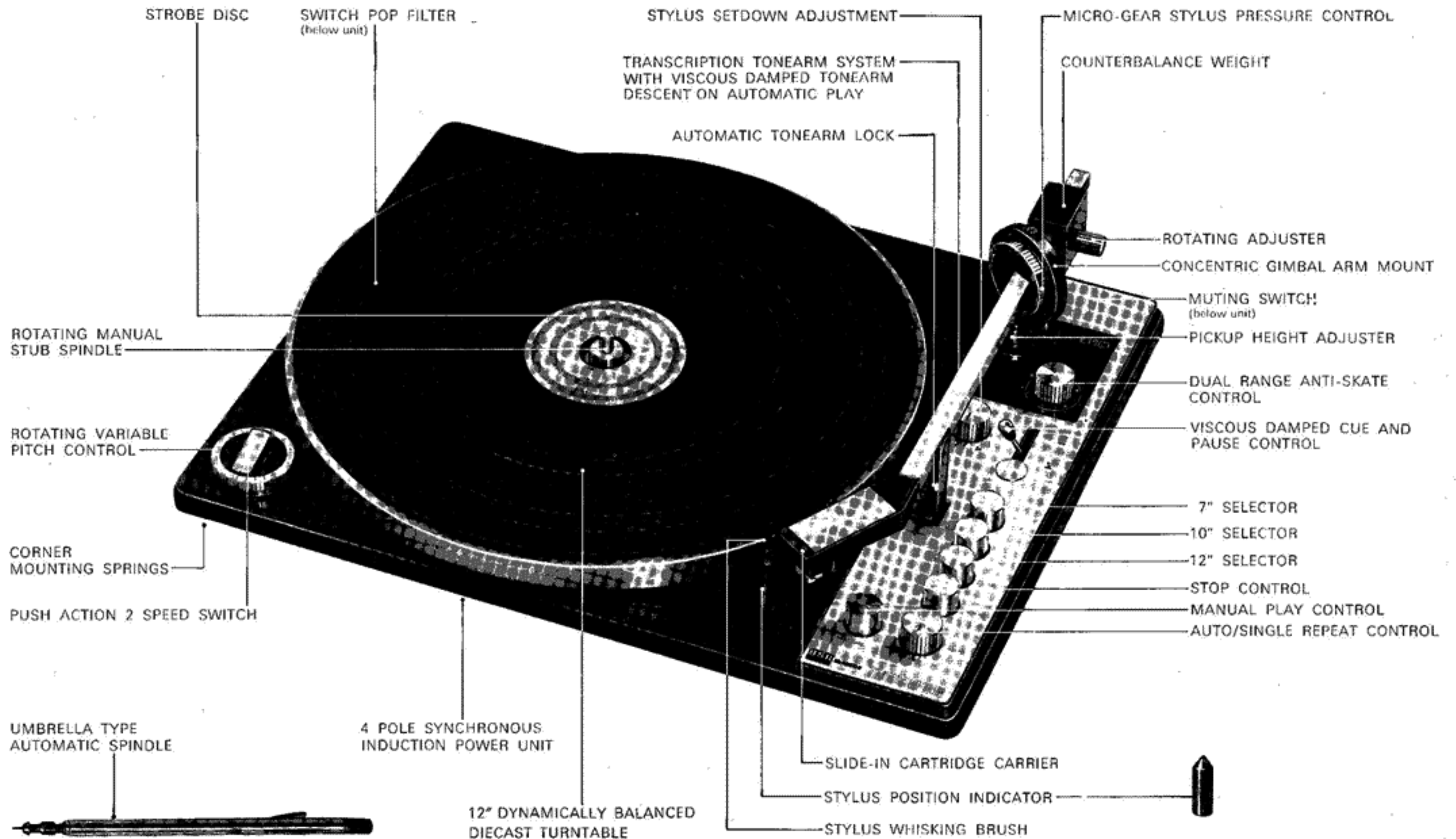

UNPACKING

This unit was carefully checked before leaving the factory. Check the condition of the packing materials for signs of improper handling in transit. If damage is apparent notify the dealer from whom you purchased the equipment. Check that all items shown on the Packing List are included.

Note: In countries where only one mains frequency is used the alternative frequency motor pulley and its matching turntable center disc stroboscope may not be included.

INSTALLATION

The BSR McDonald series of Transcription Units may be purchased as 'Chassis' models (unmounted) or 'Total Turntables' ready mounted on custom designed base (U.S.A. only). If you purchased your unit ready mounted in base ignore paragraphs 1 to 4 below.

- 1 Prepare motor board using template supplied with the unit and secure in final position in cabinet ensuring that there is a minimum depth of 73 mm (2 $\frac{7}{8}$ in) between top face of motor board and inside base of cabinet.
- 2 Fit the four rubber mountings, conical portion uppermost, into the corner holes of the motor board.
- 3 With the 'mains' and 'phono' leads passing through the motor board cut-out then out through the rear of cabinet, position the unit on the motor board with the corner springs located over the conical portion of the rubber mountings (see template).
- 4 Ensure that the unit is free to move on its springs in all directions and is not restricted by the motor board or supply cords.
- 5 Two holes are provided in the unit plate, one at the front and one at the rear of the turntable well (Fig. 2, A and B). These come directly above the two pilot holes drilled in the motor board. If it is necessary to ship or transport your unit after installation, secure it to the motor board with the two round head wood screws and fiber washers supplied.

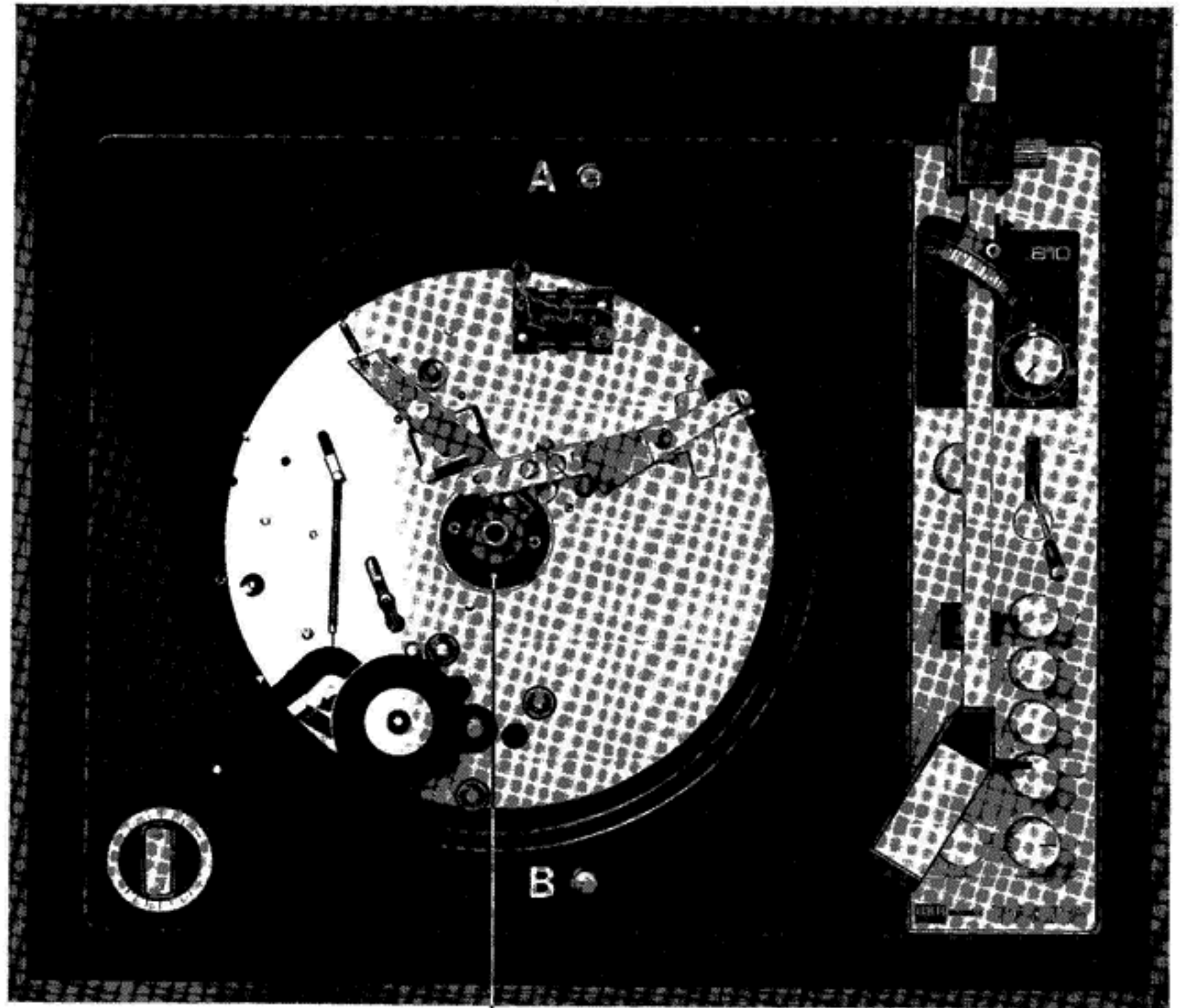

Fig. 2

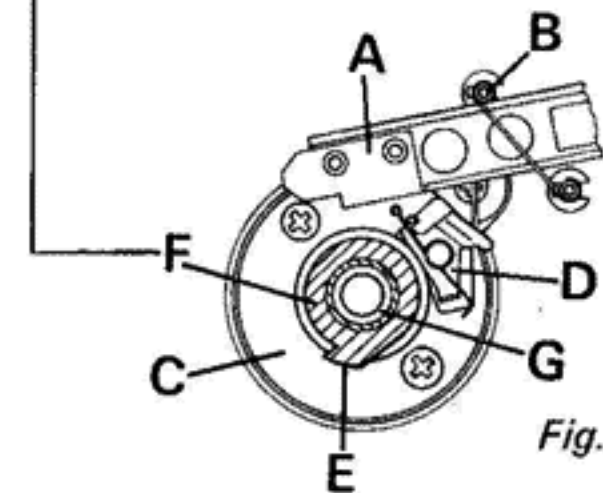

Fig. 3

ASSEMBLY

1: TURNTABLE

- Remove Transit Screws and Washers (Fig. 2, A and B) if fitted and retain for future use.
- Refer to diagram (Fig. 3).
- Push lever 'A' towards rear of unit until it stops against pin 'B'.
- If pawl 'D' is not in approximate position shown rotate bush 'C' without touching pawl 'D' until it is approximately as shown.
- Press the speed selector to position its top surface parallel to the surface of the deck.
- Push the rubber drive wheel in towards the turntable bearing 'G'.
- Wipe the inside of the turntable rim with a clean dry cloth to remove any foreign matter.
- With the projection 'E' on the turntable center boss 'F' towards the front of the unit carefully lower the turntable down onto its bearing. An oiled felt pad will slide out through the center hole, which should then be removed and discarded.
- Press speed selector to desired speed.
- Remove protective covering to expose adhesive on the strips of tape on the center of the turntable.
- Fit turntable mat by locating its center hole over raised ring in center of turntable and press down onto adhesive.
- Place appropriate 50 or 60 Hz strobe disc in position in center of rubber mat.
- Rotate the turntable by hand seven complete turns in a clockwise direction to ensure that the mechanism is in the neutral condition.

2: CARTRIDGE

The 810 cartridge slide will accept most modern cartridges weighing up to 12 grams and having standard mounting specifications.

- Remove cartridge slide from tonearm head by gripping sides of slide and pulling gently forward while supporting the tonearm (Figs. 4 and 5).
- Push slide assembly lead tags on to the appropriate cartridge terminals.
The 'Red' lead tag connects to the Right channel plus cartridge terminal. The 'Green' lead tag connects to the Right channel minus cartridge terminal. The 'White' lead tag connects to the Left channel plus cartridge terminal. The 'Black' lead tag connects to the Left

channel minus cartridge terminal. The cartridge terminals should be identified by reference to the cartridge manufacturer's instructions.

- Secure cartridge to slide using two 3-48 Standard American coarse thread screws of suitable length to ensure that they do not project through the top face of the slide.
- Insert cartridge slide into tonearm head, ensuring that it is engaged in tracks of head and fully seated.
- Check that the stylus point is within $\frac{1}{32}$ of an inch of the top of the stylus position indicator by carefully moving the tonearm to that position (Fig. 6).
- Should the stylus point position not coincide with the stylus position indicator then the cartridge should be secured to the cartridge adaptor (Fig. 7) and this in turn secured to the cartridge slide by means of the countersunk screw and washer supplied, passing through the slot in the slide and into the adaptor. The adaptor position on the slide may be varied by sliding backwards or forwards before tightening the screw.
- After attaching cartridge and adaptor to slide, the slide should be fitted into the tonearm head and the stylus position checked against the stylus position indicator. If adjustment is needed remove the slide from the head, loosen the screw securing adaptor to slide, move the adaptor backwards or forwards as required, retighten the screw and replace slide into tonearm head. Check that the stylus position is now correct, if not, readjust.

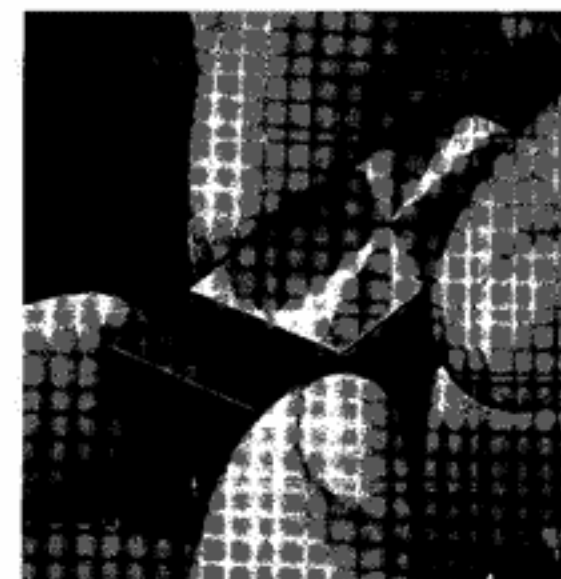

Fig. 4

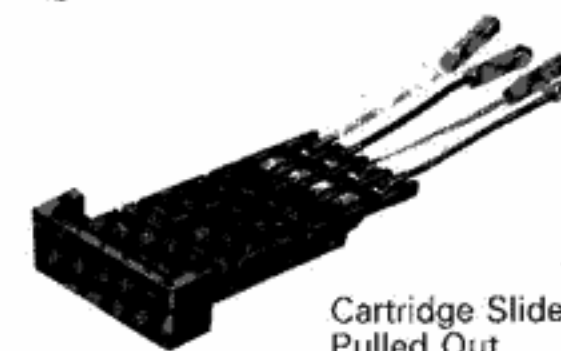

Fig. 5

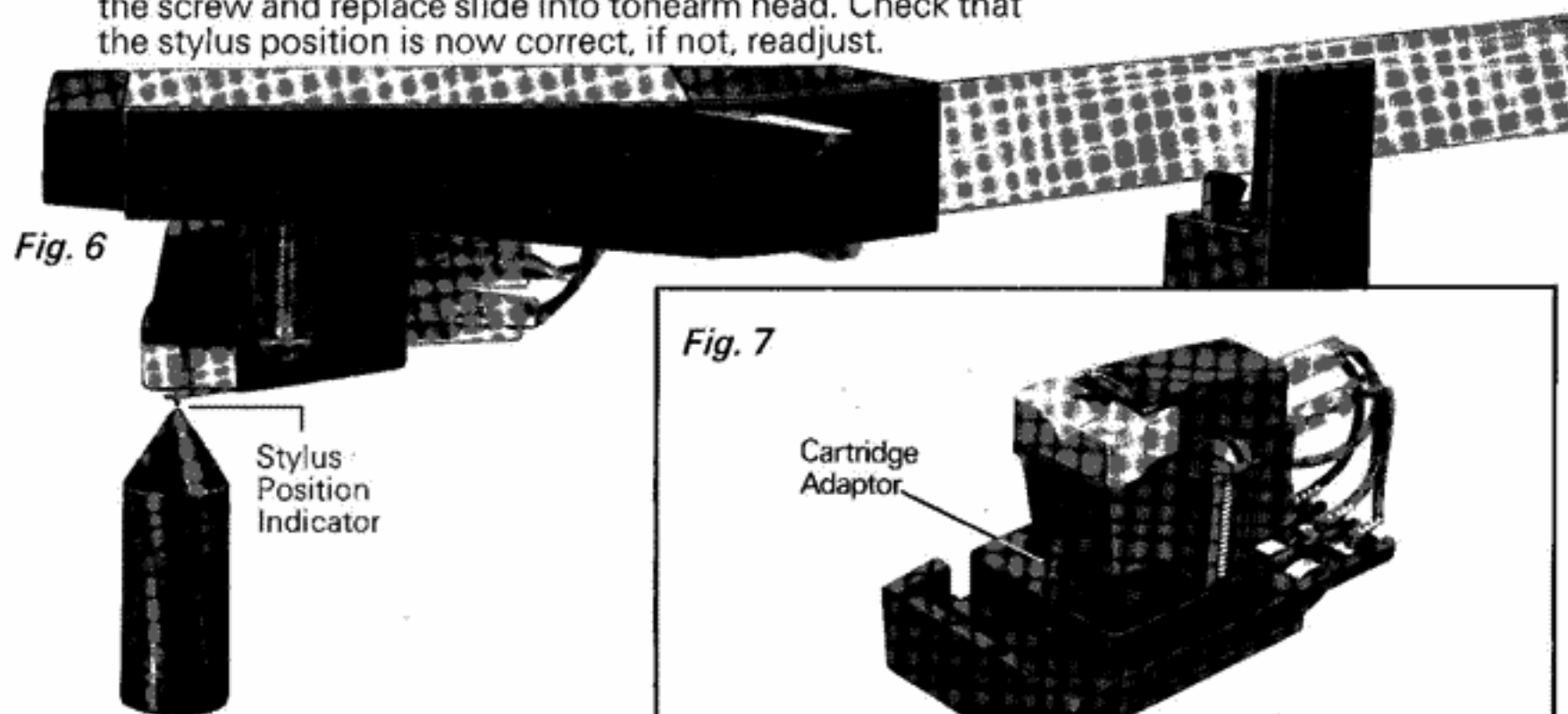

Fig. 6

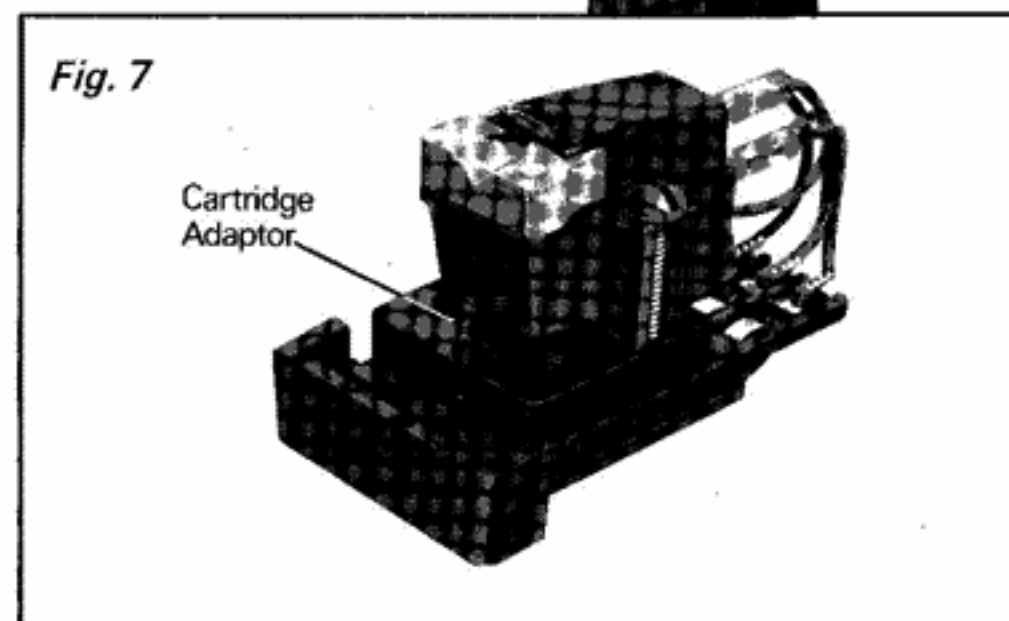
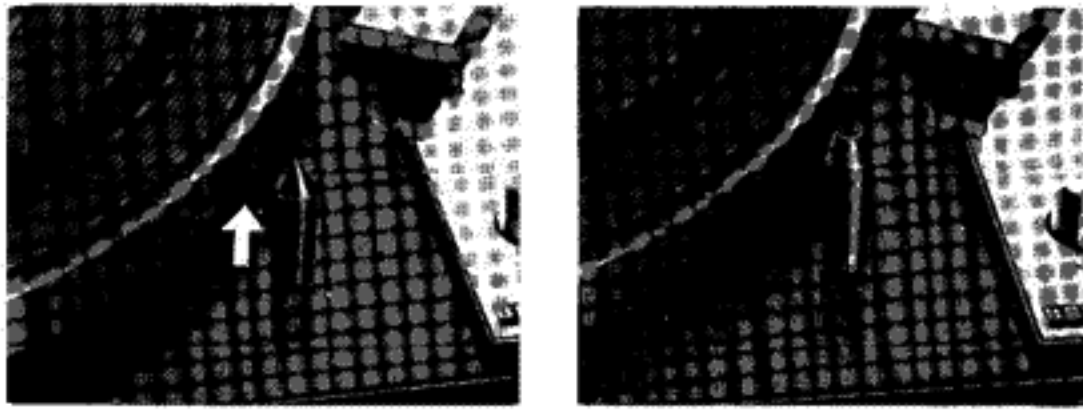

Fig. 7

3: STYLUS CLEANING BRUSH



After setting the stylus position the stylus position indicator should be removed by gently pulling upwards off its locating stud and replaced by the stylus cleaning brush.

4: TONEARM BALANCE WEIGHT

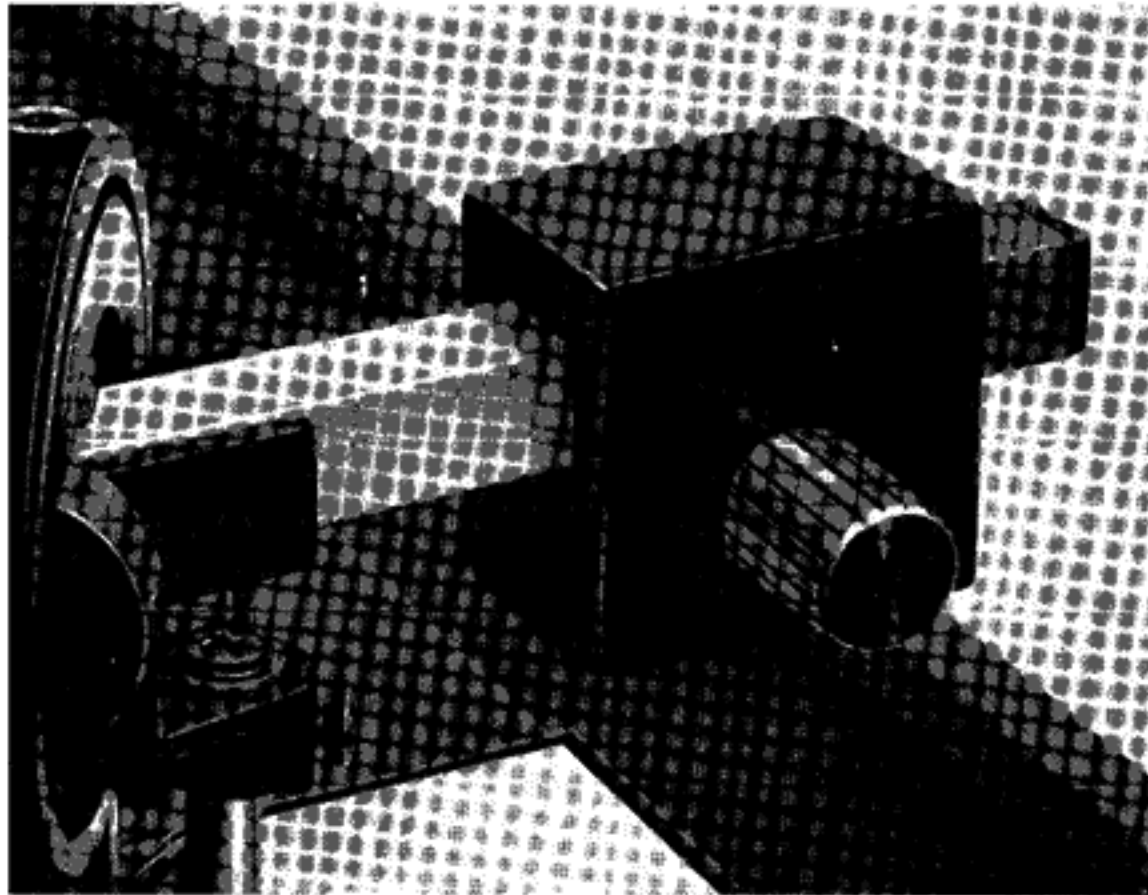

The counterbalance weight simply slides over the tonearm tube as shown in Fig. 9. Its position on the tube may be varied to balance the tonearm by turning the knob at the side. (Refer to Tonearm Balance Adjustment on Page 6.)

5: AUTOMATIC RECORD CHANGER SPINDLE

- CAUTION. Do not attempt to insert or remove spindle while unit is in cycle. Ensure mechanism is in neutral condition by rotating the turntable seven complete turns in a clockwise direction.
- Insert pointed end of spindle into hollow center bearing of turntable and let it fall gently to its seating.

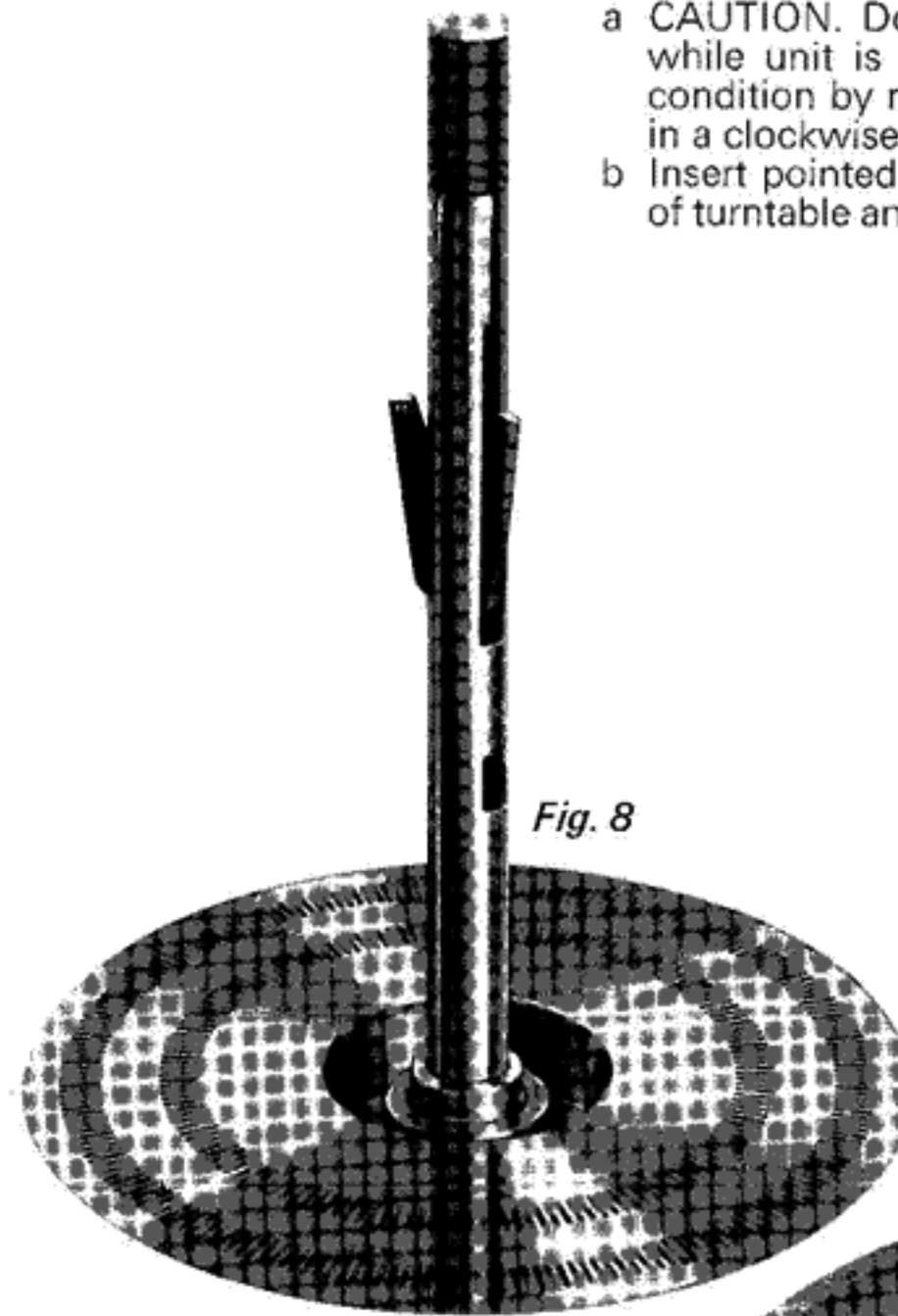

Fig. 8

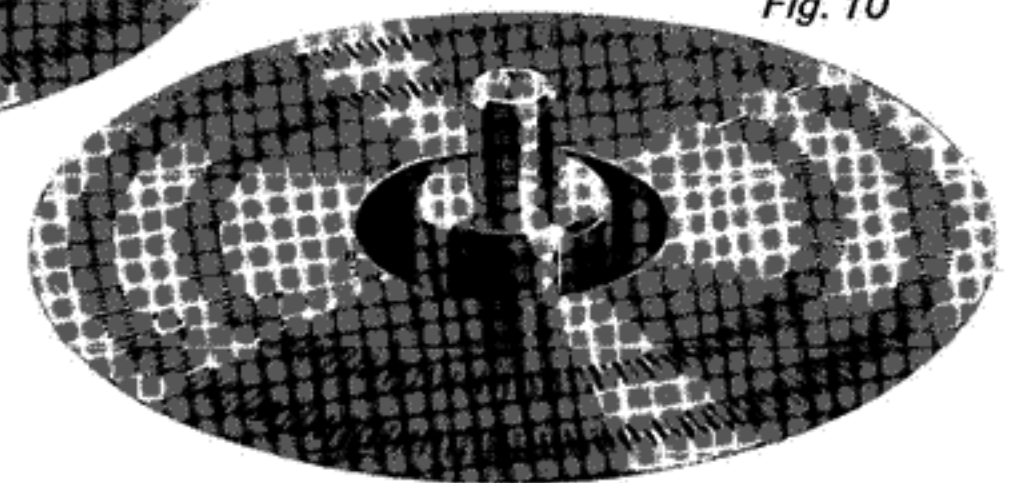

Fig. 10

6: SINGLE RECORD SPINDLE

Push hollow end over center bearing of turntable ensuring that it is correctly seated.

Fig. 9

ADJUSTMENTS

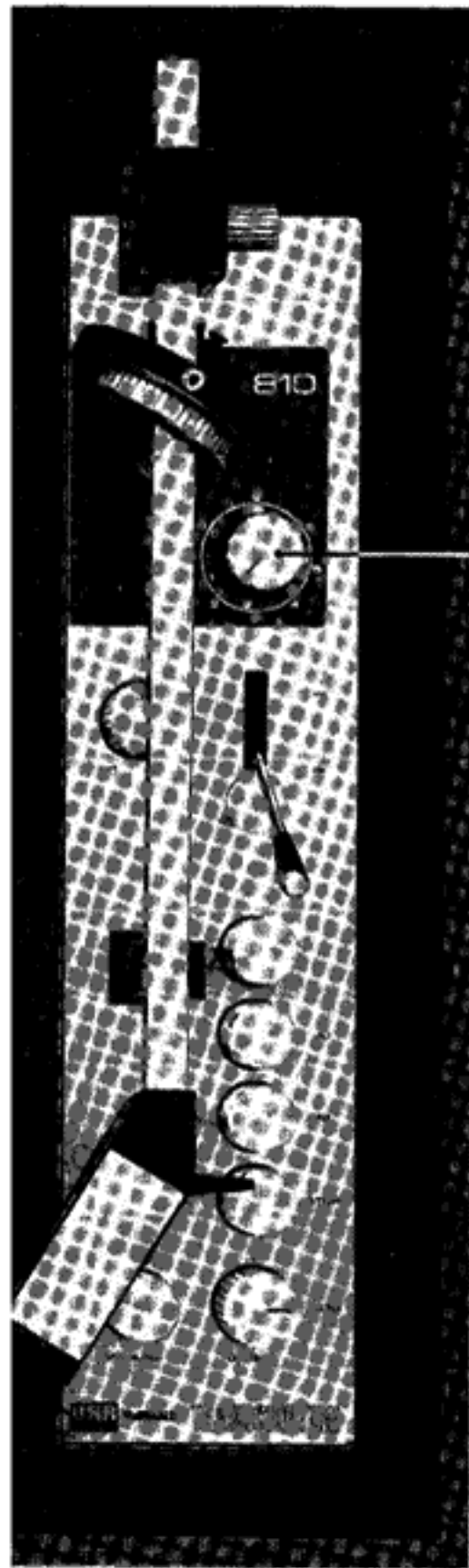

Fig. 11

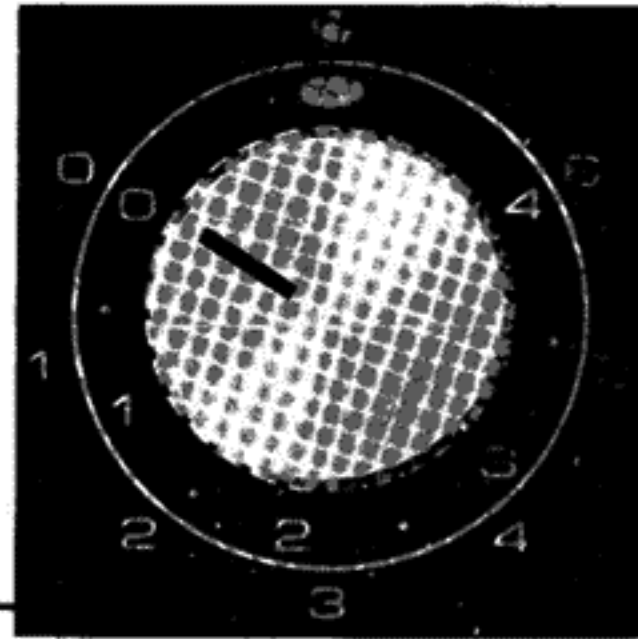
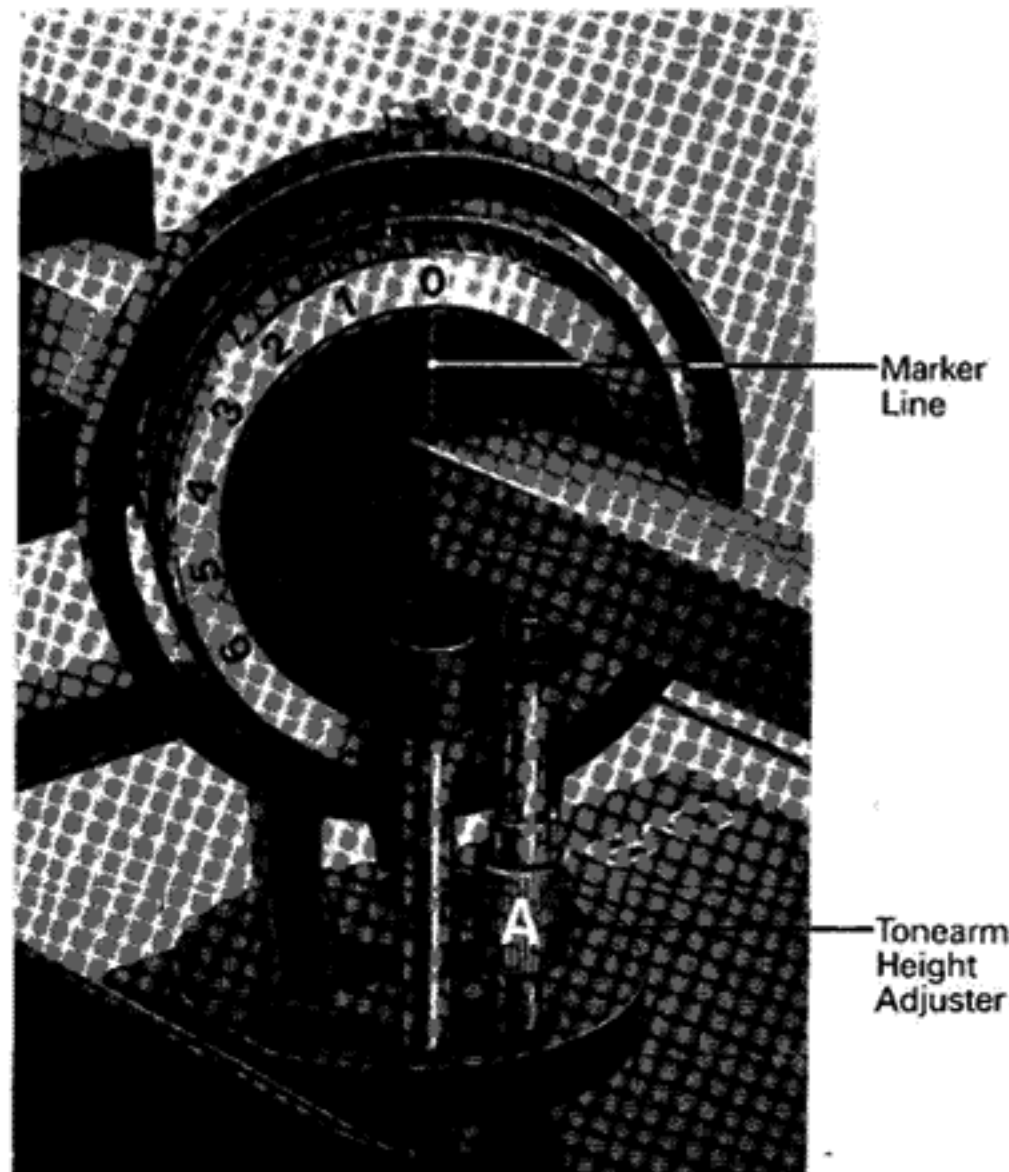

Fig. 12



1: TONEARM BALANCE

- Set the anti-skate control to '0' (Fig. 11).
- Set the stylus pressure ring to '0' (Fig. 12).
- Release tonearm from rest post by gently lifting tube clear of clip. Carefully remove stylus guard (if fitted) and move tonearm inwards until stylus point is approximately 1 in. inside edge of turntable.
- Rotate tonearm balance knob (Fig. 9) to move the weight along the tube until the tonearm balances horizontally. It is advisable to hold the tonearm head steady during adjustment of the weight although it must be released to check the actual balance.

2: STYLUS PRESSURE

Rotate stylus pressure ring until the figure for the appropriate stylus pressure in grams coincides with the marker line (Fig. 12). Always set the stylus pressure to that recommended by the manufacturer of the cartridge being used.

3: ANTI-SKATE CONTROL

Separate scales are provided for elliptical styli (designated by the symbol ●) and conical styli (designated by the symbol ●). Using the appropriate scale for the type of stylus being used, set the anti-skate control marker (Fig. 11) to coincide with figure corresponding to the stylus pressure applied. The control is continuously variable so that settings between the figures indicated are possible.

Note: The settings described are those required under ideal conditions. Slight variations from the optimum may be necessary depending on the condition of the stylus. If after setting the tonearm tends to skate out, lower the setting. If it skates in, increase the setting.

4: STYLUS SETDOWN

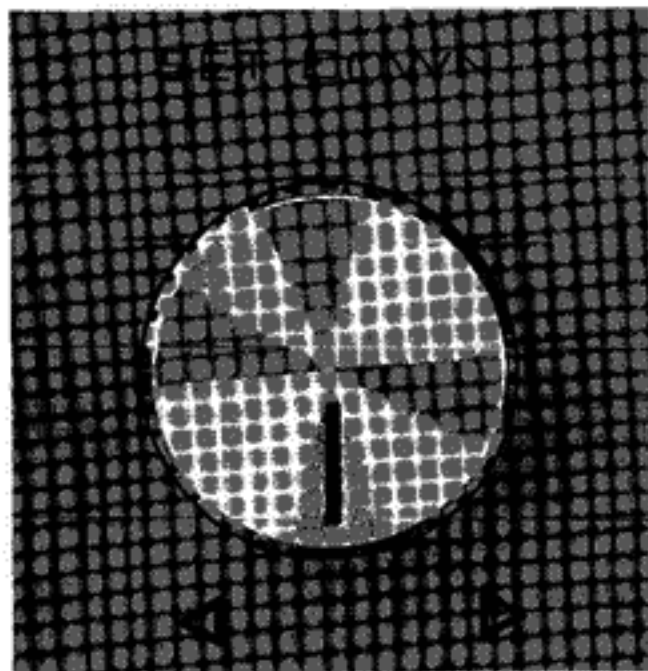

Fig. 13

The stylus setdown is correct when the stylus sets down $\frac{1}{8}$ in. in from the selected size of record (Fig. 13). Adjust as follows:

- Using the single record spindle, place record on turntable.
- Set single/auto knob to 'single'.
- Press appropriate button for the size of record being used.
- Rotate turntable clockwise by hand. The tonearm will lift, move inwards and lower itself towards the record.
- When the stylus point is approximately $\frac{1}{8}$ in. above the record stop the turntable.
- If the stylus point is not directly above the correct point on the record, rotate the setdown adjuster clockwise to move the stylus closer to the record center or anti-clockwise to move it closer to the record edge.
- When the desired position is reached rotate the turntable until the stylus sets down on the record and runs in the groove.
- Lift tonearm and replace stylus in finishing groove of record.
- Continue to rotate the turntable until the tonearm lifts, returns to the rest and the mechanism returns to the neutral condition.

Note: When adjusted correctly for one size of standard record the setdown should be correct for other standard size records.

5: TONEARM HEIGHT

The tonearm height is correctly set when there is a gap of $\frac{7}{32}$ in. between the underside of the tonearm tube and its seating face on the rest when the tonearm is raised to its fullest height as the mechanism cycles (Fig. 14). Adjust as follows:

- Press 12 in. selector button.
- Rotate turntable clockwise by hand until the tonearm lifts up from its rest to its fullest height and immediately stop rotating turntable.
- Adjust height by turning the knurled sleeve under the stylus pressure rim counter-clockwise (viewed from the top) to raise the arm, clockwise to lower it (Fig. 12, A).

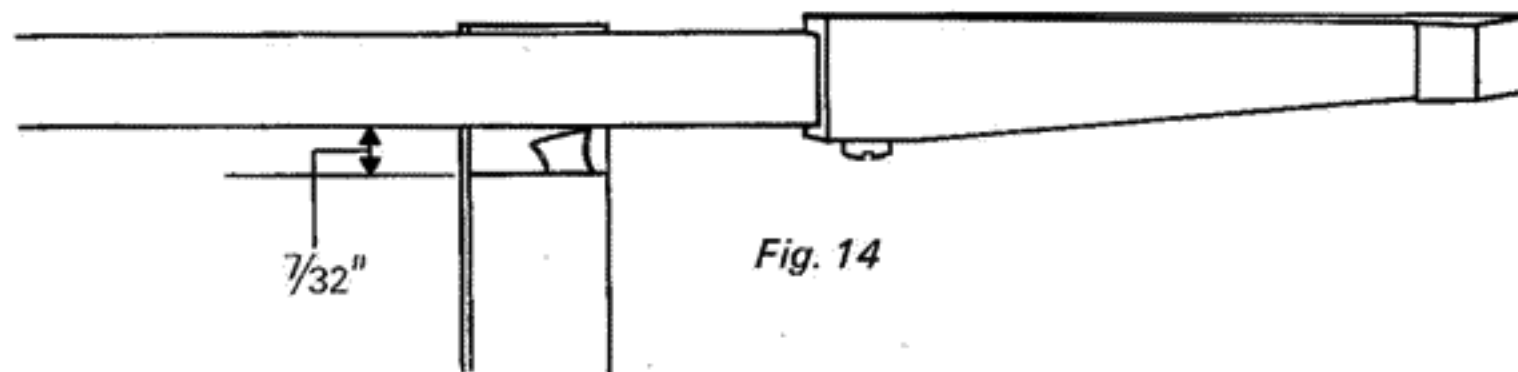

6: TURNTABLE SPEED



Fig. 15



Each of the turntable speeds (45 and $33\frac{1}{3}$) may be varied through a range of approximately 6%.

To set the turntable speed accurately at either speed it is necessary to have an electric light source of the same frequency as your unit (50 or 60 Hz) directly above the turntable.

- Connect unit to power source.
- Press the manual button and the turntable will revolve.
- Observe the appropriate 45 or $33\frac{1}{3}$ ring of bars on the center disc stroboscope (Fig. 15).
- The turntable speed is correct when they appear as stationary individual bars.
- If the bars move clockwise, the turntable speed is too fast and can be reduced by turning the pitch control clockwise (Fig. 18).
- If the bars move anti-clockwise the speed is too slow and can be increased by turning the pitch control anti-clockwise.

CONNECTIONS

1: PHONO PICKUP

The pickup leads are terminated in phono plugs. These are standard and should fit the input sockets to most amplifiers. The Black plug should be plugged into the right hand channel input of the amplifier and the Gray plug into the left hand channel input.

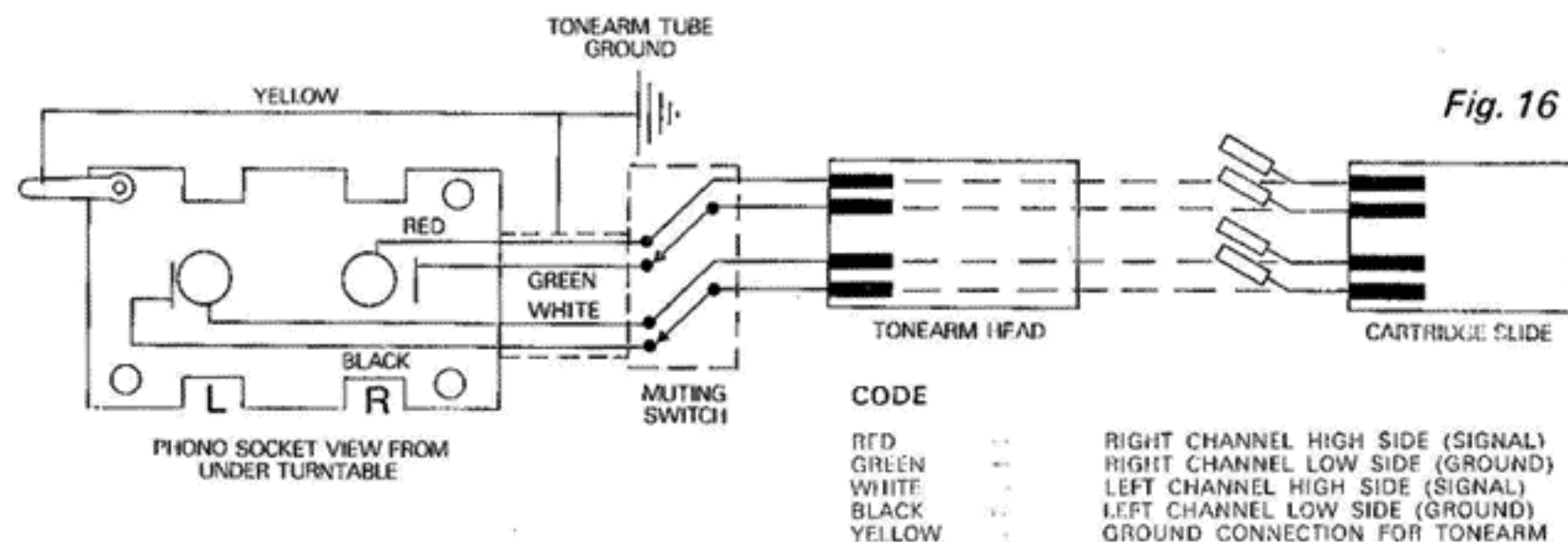

Fig. 16

2: POWER SUPPLY

The power input is a two core lead fitted with a standard American two pin plug which fits the power output sockets of most amplifiers. If the plug is not suitable replace with one suitable for your power source. A separate earth lead (Green or Green and Yellow) is provided. This should be connected to an earth point on the amplifier chassis. In some cases, where the amplifier already has an earth connection, the earth lead from the unit might create a hum loop and in these circumstances this lead can be ignored.

3: VOLTAGE

All turntables have power units which can be connected for operation on either 120 or 240 volts. To convert your unit for operation on either voltage it is only necessary to reposition the leads in the connectors secured to the side of the speed change bracket on the underside of unit. Refer to diagrams for actual connections. If individual connectors are used to join leads, these may be removed by unscrewing in an anti-clockwise direction. For 120v connections two connectors are used, for 240v connections three connectors are used.

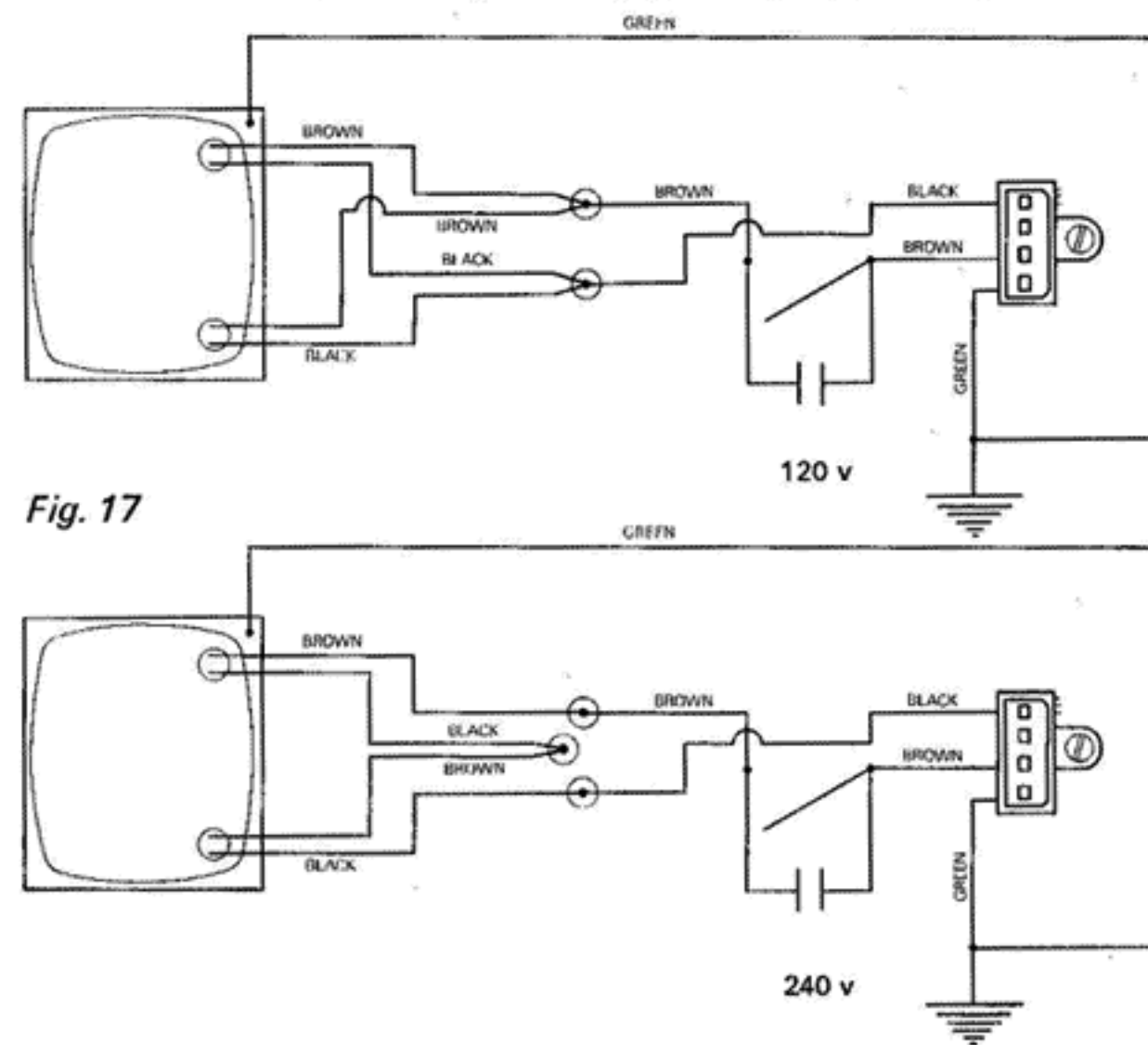

Fig. 17

OPERATING INSTRUCTIONS

CAUTION

- a Do not attempt to insert or remove automatic center spindle while the unit is in cycle. It is advisable to rotate the turntable manually seven complete turns whenever there is any doubt that the change cycle is complete.
- b Do not operate the controls while unit is in cycle.
- c To give time for the tonearm to return completely to the rest there is a delay built into the tonearm clip. As a result the clip action may not be felt for several seconds after the tonearm has lowered onto the rest.

1: SPEED CHANGE

The speed change is the rocker switch type, the desired speed being selected by pressing down the appropriate number.

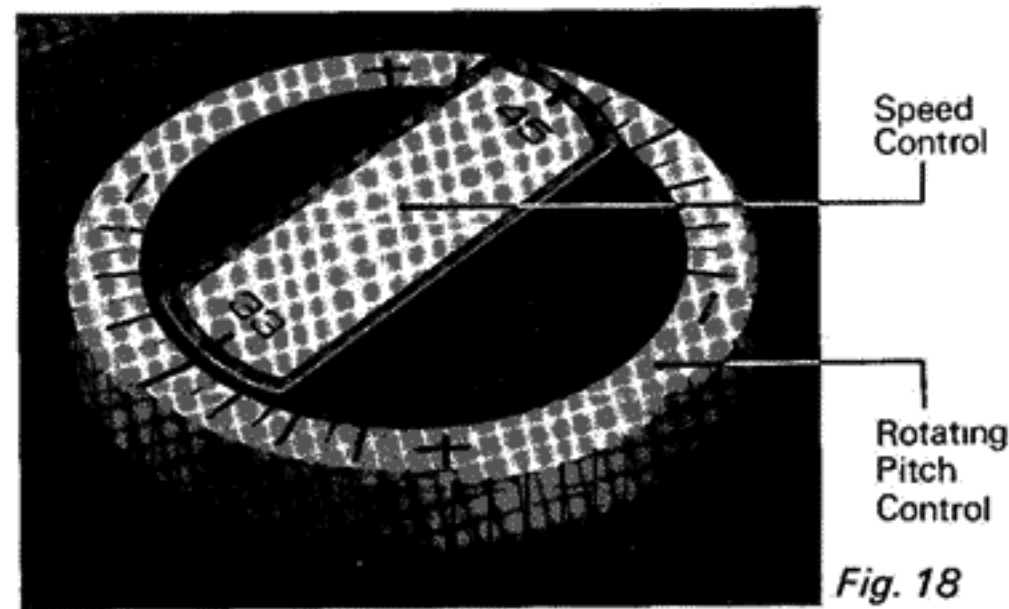

Fig. 18

2: AUTOMATIC PLAY

- a Set speed selector to required speed.
- b Set auto/single knob to 'auto'.
- c Insert automatic spindle (Fig. 8).
- d Load records onto spindle. All records must be same size and speed and the stack thickness should not exceed 0.450 in.
- e Press the appropriate size selector button corresponding to the size of records loaded. The unit will play records in sequence and at the end of the last record the tonearm will return to the rest, the unit will switch off, automatically clipping the tonearm to its rest.
- f Remove center spindle.
- g Remove records from turntable.
- h Replace center spindle.

3: AUTOMATIC SINGLE PLAY

- a Set speed selector to required speed.
- b Set auto/single knob to 'single'.
- c Fit single record spindle (Fig. 10).
- d Place record on turntable.
- e Press appropriate size selector button.
- f The tonearm will automatically set down on the selected diameter, play the record, return to the rest and switch off.

4: REPEAT FACILITY

If the above single play sequence is carried out with the auto/single knob set at 'auto' the unit will play through the record and repeat until the 'stop' button is pressed, after which the tonearm will return to the rest and the unit will switch off.

Note: The repeat facility operates only when the single record spindle is used and NOT with the automatic changer spindle.

5: MANUAL SINGLE PLAY

- a Set speed selector to required speed.
 - b Set auto/single knob to 'single'.
 - c Fit single record spindle.
 - d Place record on turntable.
 - e Press 'manual' button. The turntable will now rotate.
 - f The tonearm may now be manually removed from the rest and placed on any desired point on the record. It is advisable to use the cueing lever for this operation (Fig. 19).
- Note:* Care needs to be exercised when manually selecting the last portion of the record in order not to activate the sensitive tripping mechanism which initiates the automatic cycle.

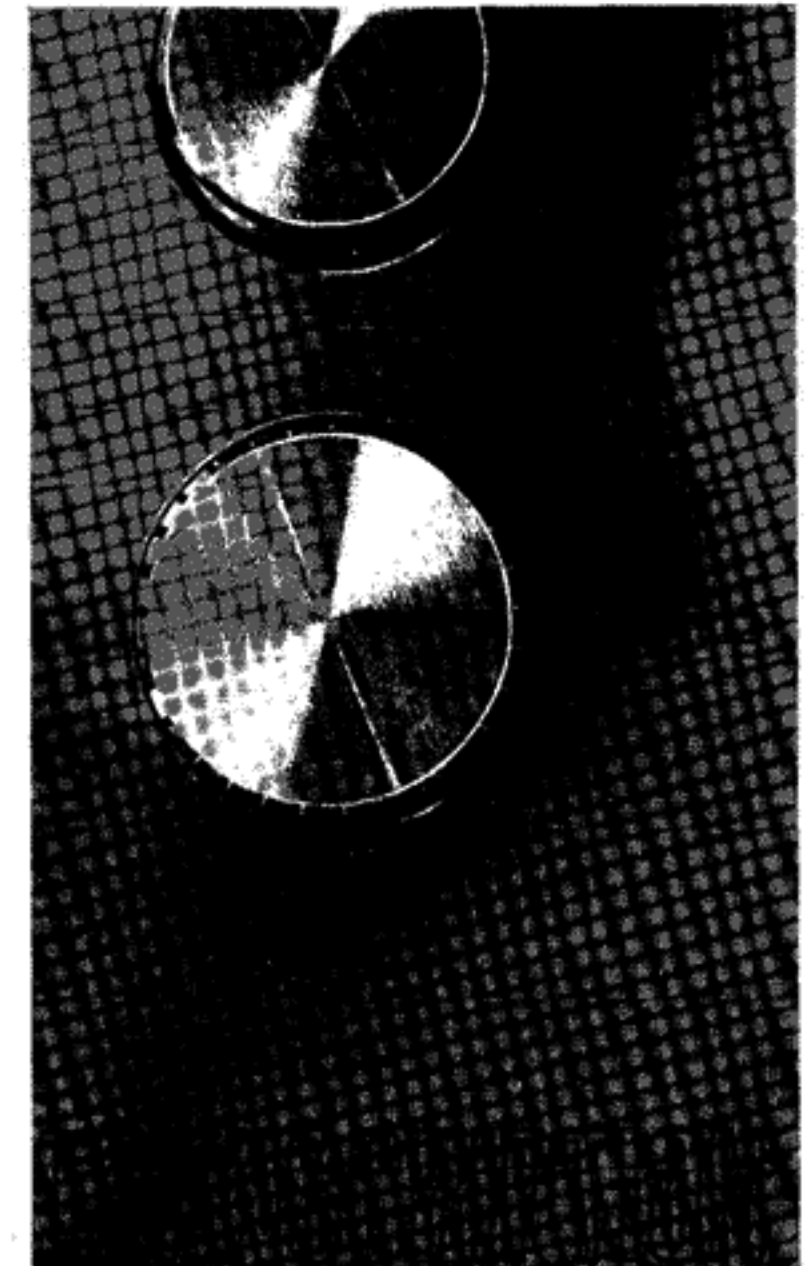

6: CUEING LEVER

Fig. 19

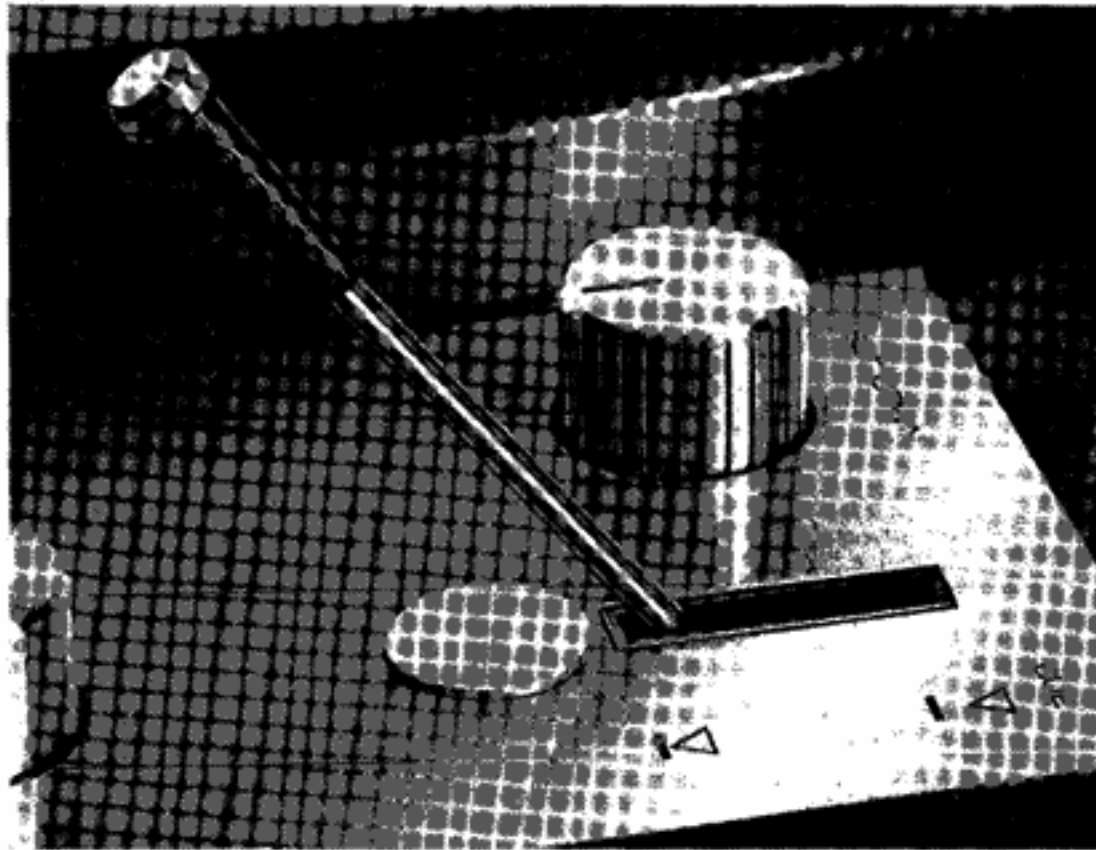

When the cueing lever is moved backwards the tonearm is released from its locked position. It may then be manually moved to the desired point over the record. Returning the cueing lever forward allows the tonearm to lower slowly onto the record. This gentle slow downward motion is controlled by the viscous damped mechanism. The cueing lever may also be used as a 'pause' control to interrupt play at any time.

FREQUENCY CHANGE

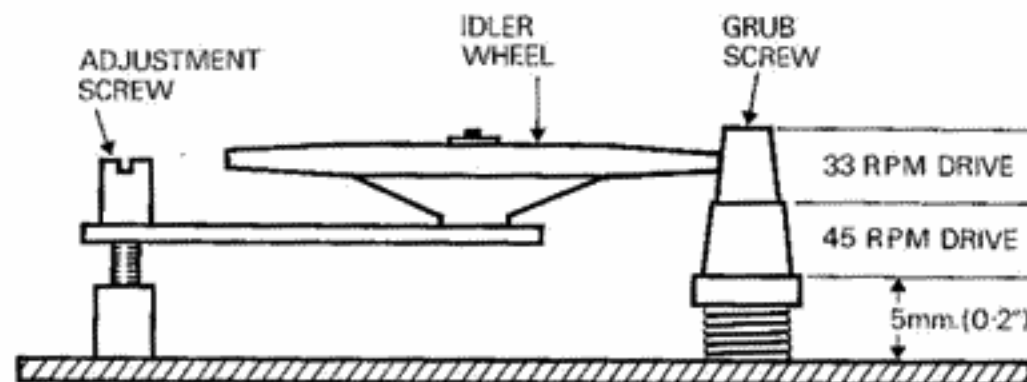

Fig. 20

Units are available for operation on either 50 or 60 Hz. To change from one to the other it is necessary to change the brass motor pulley accessible after removing the turntable.

- The pulley is held onto the motor shaft by a spring. To remove pulley pull it upwards while twisting in an anti-clockwise direction.
- To replace pulley. There is a grub screw through the center of the smaller end. This should be unscrewed until its slotted end projects approximately $\frac{1}{8}$ in. out of the brass pulley. The pulley (with the spring attached) is pushed onto the motor shaft as far as it will go, while twisting in an anti-clockwise direction. The grub screw should then be screwed into the pulley to raise the pulley to the dimension shown in Fig. 20.
- Set the pitch control to its middle position (see Fig. 18), the speed selector to '33' and then adjust the height of the rubber drive wheel to be central on the smaller diameter of the pulley by turning screw clockwise to lower or anti-clockwise to raise. Refit the turntable.

LUBRICATION

This unit has been thoroughly lubricated at the factory and under normal use should not require additional lubrication. However, after prolonged use it may be necessary to lubricate the rubber drive pulley bearing, the turntable bearing and the top and bottom motor bearings sparingly with a light machine oil.

WARNING! Do not allow oil to get onto rubber drive wheel or drive surface of turntable.

SERVICE

Should your unit require service contact the dealer from whom you purchased it. The following hints may help remedy minor faults.

SYMPTOM	CAUSE	REMEDY
Turntable does not revolve when selector buttons are pressed.	1. No voltage to motor. 2. Defective motor.	Check power source. Check motor, repair or replace.
Tonearm does not track across record.	1. Stylus clogged with dust. 2. Stylus damaged. 3. Too low stylus pressure. 4. Damaged record.	Remove dust. Replace stylus. Check and adjust. Replace record.
Uneven turntable speed.	1. Oil or grease on rubber drive wheel or drive rim of turntable. 2. Stiff drive wheel bearing.	Clean with soft cloth. Free bearing and lightly lubricate.